

75

BGE series

75X75X15mm



● General Specification

- Motor / DC single phase brushless motor
- Material / Frame : PBT (94V-0) ; Impeller : PBT(94V-0)
- Operation temp. / Two ball bearing : -10°C~70°C
FMB,sleeve Bearing : -10°C~50°C
- Storage temp. / -40°C~80°C
- Non-condensing environment
- Weight /85g

● Specification *Bearing system B:two ball bearing F:fluid bearing S:sleeve bearing

Model	Bearing System	Rated Voltage	Operating Voltage Range	Rated Current	Rated Speed	Maximum Air Flow		Maximum Static Pressure		Sound Level	P-Q Curve
Part No.	B / S / F	V	V	A	RPM	m ³ /min	CFM	Pa	In-H ₂ O	dBA	No.
BGE07015_12L	B	12	7.0~13.2	0.21	4000	0.21	7.4	60.8	0.24	43	①
BGE07015_12M	B	12	7.0~13.2	0.32	4500	0.27	9.7	135.3	0.54	47	②
BGE07015_12H	B	12	7.0~13.2	0.40	5000	0.31	10.8	167.6	0.67	49	③
BGE07015_12U	B	12	7.0~13.2	0.50	5500	0.34	11.9	202.9	0.81	51	④

● Drawing

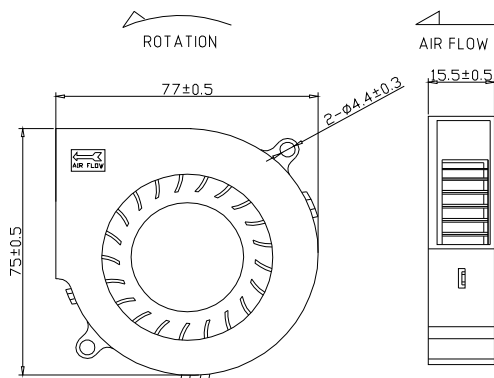

Unit:mm

● Characteristic Curves

