

97

BGE series

97X97X33mm

● General Specification

- Motor / DC single phase brushless motor
- Material / Frame : PBT (94V-0) ; Impeller : PBT(94V-0)
- Operation temp. / Two ball bearing : -10°C~70°C
FMB,sleeve Bearing : -10°C~50°C
- Storage temp. / -40°C~80°C
- Non-condensing environment
- Weight / 150g



● Specification *Bearing system B:two ball bearing F:fluid bearing S:sleeve bearing

Model	Bearing System	Rated Voltage	Operating Voltage Range	Rated Current	Rated Speed	Maximum Air Flow		Maximum Static Pressure		Sound Level	P-Q Curve
Part No.	B / S / F	V	V	A	RPM	m ³ /min	CFM	Pa	In-H ₂ O	dBA	No.
BGE09733_12L	B/S	12	7.0~13.2	0.21	2200	0.46	16.3	59.8	0.24	43	①
BGE09733_12M	B/S	12	7.0~13.2	0.32	2700	0.57	20.1	99.6	0.40	45	②
BGE09733_12H	B/S	12	7.0~13.2	0.60	3600	0.62	28.8	283.9	1.14	52	③
BGE09733_24L	B/S	24	14.0~26.4	0.14	2200	0.46	16.3	59.8	0.24	43	①
BGE09733_24M	B/S	24	14.0~26.4	0.18	2700	0.57	20.1	99.6	0.40	45	②
BGE09733_24H	B/S	24	14.0~26.4	0.32	3600	0.62	28.8	283.9	1.14	52	③

● Drawing

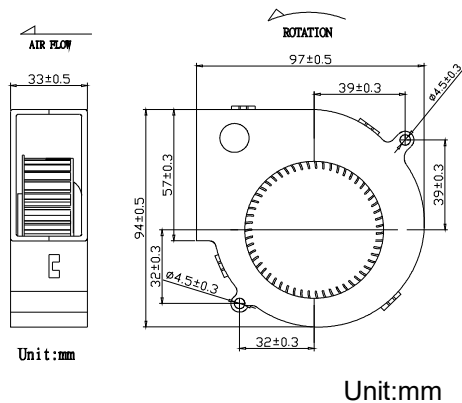

● Characteristic Curves

