

120 BGE series

120X120X32mm

● General Specification

- Motor / DC single phase brushless motor
- Material / Frame : PBT (94V-0) ; Impeller : PBT(94V-0)
- Operation temp. / Two ball bearing : -10°C~70°C
FMB,sleeve Bearing : -10°C~50°C
- Storage temp. / -40°C~80°C
- Non-condensing environment
- Weight / 230g



● Specification *Bearing system B:two ball bearing F:fluid bearing S:sleeve bearing

Model	Bearing System	Rated Voltage	Operating Voltage Range	Rated Current	Rated Speed	Maximum Air Flow	Maximum Static Pressure	Sound Level	P-Q Curve		
Part No.	B / S / F	V	V	A	RPM	m ³ /min	CFM	Pa	In-H ₂ O	dBA	No.
BGE12032_12L	B	12	7.0~13.2	0.40	2100	0.70	24.6	139.4	0.56	45	①
BGE12032_12M	B	12	7.0~13.2	0.58	2500	0.82	28.8	206.7	0.83	47	②
BGE12032_12H	B	12	7.0~13.2	1.11	2800	0.91	32.1	263.9	1.06	49	③
BGE12032_12U	B	12	7.0~13.2	1.25	3100	1.06	37.5	321.2	1.29	52	④

● Drawing

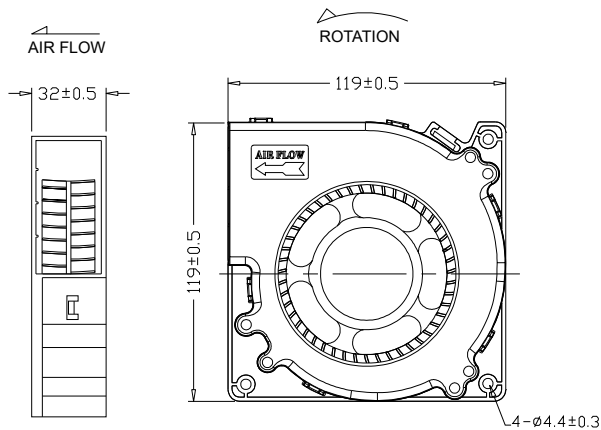

Unit:mm

● Characteristic Curves

