

175 BG series

Ø175X68.5mm

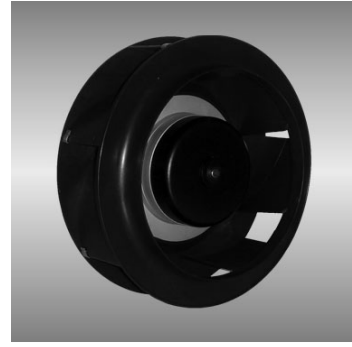

● General Specification

- Motor / DC brushless motor
- Material / Frame : die cast aluminum ; Impeller : plastic(94V-0)
- Rotational direction CW view from front face
- Bearing / Two ball precision bearing
- Insulator class "B"
- Weight / 0.7kg

● Specification

Model	Bearing System	Rated Voltage	Rated Current	Rated Speed	Maximum Air Flow		Maximum Static Pressure		Sound Level	P-Q Curve
Part No.	B / S / F	V	A	RPM	m ³ /hr	CFM	Pa	In-H ₂ O	dBA	No.
BGN17569B24H	B	24	1.5	3300	594	350	389	1.56	67	①
BGN17569B48H	B	48	1.2	3300	594	350	389	1.56	67	①
BGN17569B48U	B	48	1.2	4200	693	408	618	2.48	72	②

● Drawing

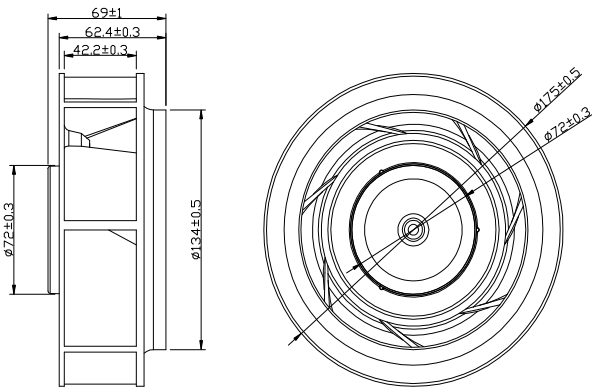

● Characteristic Curves

