

190 BG series

Ø190X68.5mm



● General Specification

- Motor / DC three-phase brushless motor
- Material / Frame : die cast aluminum ; Impeller : plastic(94V-0)
- Rotational direction CW view from front face
- Bearing / Two ball precision bearing
- Insulator class "B"
- Weight / 1.0kg(BGN); 1.3kg(BGM)

● Specification

Model	Bearing System	Rated Voltage	Rated Current	Rated Speed	Maximum Air Flow		Maximum Static Pressure		Sound Level	P-Q Curve
Part No.	B / S / F	V	A	RPM	m ³ /hr	CFM	Pa	In-H ₂ O	dBA	No.
BGN19069B24U-72	B	24	3.5	3000	630	371	495	1.99	68	①
BGN19069B48U-72	B	48	1.8	3000	630	371	495	1.99	68	①
BGM19069B24U-92	B	24	3.5	3000	500	294	600	2.41	73	②
BGM19069B48U-92	B	48	1.8	3000	500	294	600	2.41	73	②

● Drawing

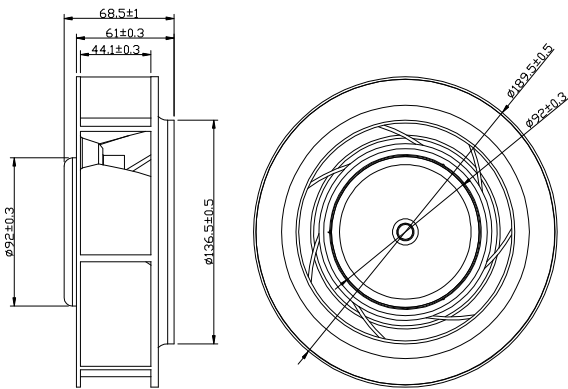

● Characteristic Curves

