

254 IGE series

254X89mm



General Specification

- Motor / Outer rotor induction capacitor motor
- Material / Frame: Al alloy
Impeller: PBT plastic
- Insulation / Class 'B' or 'F'
- Connection / Lead wires
- Weight / 2000 g

Model	Motor Type	Bearing System	Rated Voltage	Frequency	Watt	Rated Speed	Maximum Air Flow	Maximum Static Pressure	Sound Level		
Part No.	○/◎	B / S / F	V	Hz	W	RPM	m ³ /min	CFM	mm-H ₂ O	In-H ₂ O	dBA
IGE25489B1H	◎	B	110	50/60	60/67	2150/2000	17.8/19.87	628/702	17.9/18.7	0.70/0.74	54/56
IGE25489B2H	◎	B	230	50/60	60/67	2150/2000	17.8/19.87	628/702	17.9/18.7	0.70/0.74	54/56
IGE25489B1M	◎	B	110	50/60	60/67	1400/1600	13.0/15.3	458/541	13.3/14.4	0.52/0.57	49/51

Motor type ○:shaped pole AC motor/◎:capacitor induction motor

Drawing

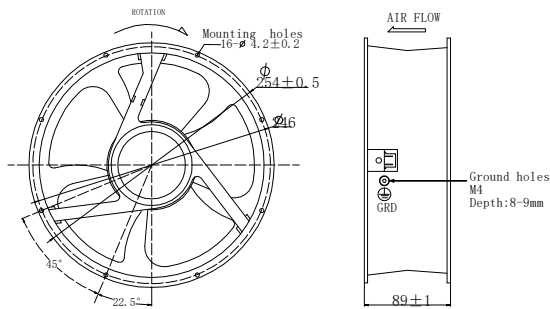

Characteristic Curves

