

30

BGE series

30X30X04mm

●General Specification

- Motor / DC single phase brushless motor
- Material / Frame : PBT (94V-0) ; Impeller : PBT(94V-0)
- Operation temp. / Two ball bearing : -10°C~70°C
FMB,sleeve Bearing : -10°C~50°C
- Storage temp. / -40°C~80°C
- Non-condensing environment
- Weight / 4g



●Specification *Bearing system B:two ball bearing F:fluid bearing S:sleeve bearing

Model	Bearing System	Rated Voltage	Operating Voltage Range	Rated Current	Rated Speed	Maximum Air Flow	Maximum Static Pressure	Sound Level	P-Q Curve		
Part No.	B / S / F	V	V	A	RPM	m ³ /min	CFM	Pa	In-H ₂ O	dBA	No.
BGE03004F05H	F	5	4.5~5.5	0.08	11000	0.03	0.9	137.7	0.55	31	①

● Drawing

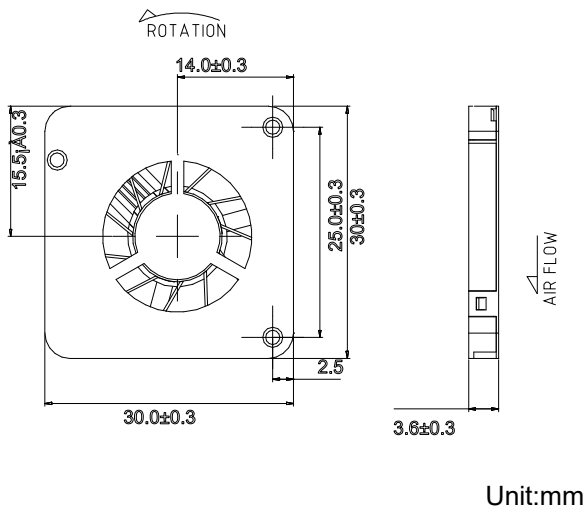

● Characteristic Curves

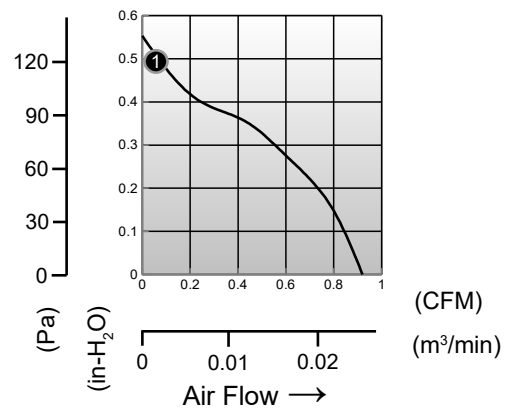

Air Pressure ↑