

35

AGE series

35X35X10mm

●General Specification

- Motor / DC single phase brushless motor
- Material / Frame : PBT (94V-0) ; Impeller : PBT(94V-0)
- Operation temp. / Two ball bearing : -10°C~70°C
FMB,sleeve Bearing : -10°C~50°C
- Storage temp. / -40°C~80°C
- Non-condensing environment
- Weight / 11g



●Specification *Bearing system B:two ball bearing F:fluid bearing S:sleeve bearing

Model	*Bearing System	Rated Voltage	Operating Voltage	Rated Current	Rated Speed	Maximum Air Flow	Maximum Static Pressure	Sound Level	P-Q Curve		
P/N	B / S / F	V	V	A	RPM	m ³ /min	CFM	Pa	In-H ₂ O	dB(A)	No.
AGE03510_05M	B / S	5	4.5~5.5	0.05	5000	0.06	2.10	17.4	0.07	18	①
AGE03510_05H	B / S	5	4.5~5.5	0.06	6000	0.09	3.17	24.9	0.10	20	②
AGE03510_05U	B / S	5	4.5~5.5	0.07	7000	0.12	4.37	34.9	0.14	23	③
AGE03510_05V	B / S	5	4.5~5.5	0.04	8000	0.16	5.51	44.8	0.18	25	④
AGE03510_05W	B / S	5	4.5~5.5	0.10	9000	0.18	6.30	54.8	0.22	28	⑤
AGE03510_12U	B / S	12	7.0~13.2	0.03	7000	0.12	4.37	34.9	0.14	23	③
AGE03510_12V	B / S	12	7.0~13.2	0.04	8000	0.16	5.51	44.8	0.18	25	④
AGE03510_12W	B / S	12	7.0~13.2	0.07	9000	0.18	6.30	54.8	0.22	28	⑤

● Drawing & panel out-cuts

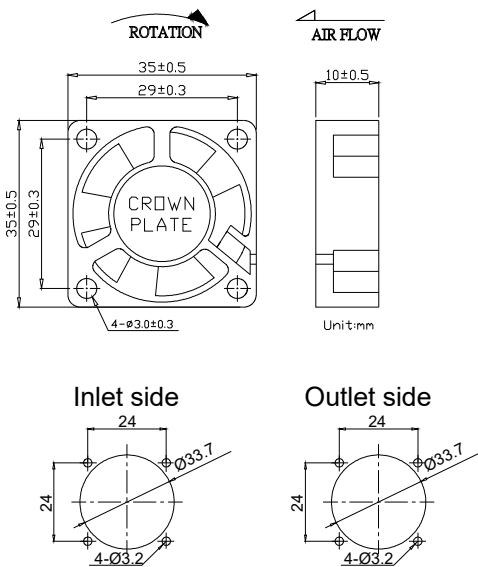

● Characteristic Curves

