

# 38

## AGE series

38X38X20mm

### ●General Specification

- Motor / DC single phase brushless motor
- Material / Frame : PBT (94V-0) ; Impeller : PBT(94V-0)
- Operation temp. / Two ball bearing : -10°C~70°C  
FMB,sleeve Bearing : -10°C~50°C
- Storage temp. / -40°C~80°C
- Non-condensing environment
- Weight / 31



### ●Specification \*Bearing system B:two ball bearing F:fluid bearing S:sleeve bearing

Model	*Bearing System	Rated Voltage	Operating Voltage	Rated Current	Rated Speed	Maximum Air Flow	Maximum Static Pressure	Sound Level	P-Q Curve		
P/N	B / S / F	V	V	A	RPM	m <sup>3</sup> /min	CFM	Pa	In-H <sub>2</sub> O	dBA	No.
AGE03820_12L	B	12	7.0~13.2	0.10	6700	0.18	6.3	53.9	0.22	36	①
AGE03820_12M	B	12	7.0~13.2	0.12	8000	0.21	7.4	84.3	0.34	40	②
AGE03820_12H	B	12	7.0~13.2	0.13	8900	0.24	8.6	98.0	0.39	42	③
AGE03820_12U	B	12	7.0~13.2	0.30	10000	0.30	10.6	145.1	0.58	43	④
AGE03820_24L	B	24	14.0~26.4	0.07	6700	0.18	6.3	53.9	0.22	36	①
AGE03820_24M	B	24	14.0~26.4	0.07	8000	0.21	7.4	84.3	0.34	40	②
AGE03820_24H	B	24	14.0~26.4	0.09	8900	0.24	8.6	98.0	0.39	42	③
AGE03820_24U	B	24	14.0~26.4	0.17	10000	0.30	10.6	145.1	0.58	43	④

### ● Drawing & panel out-cuts

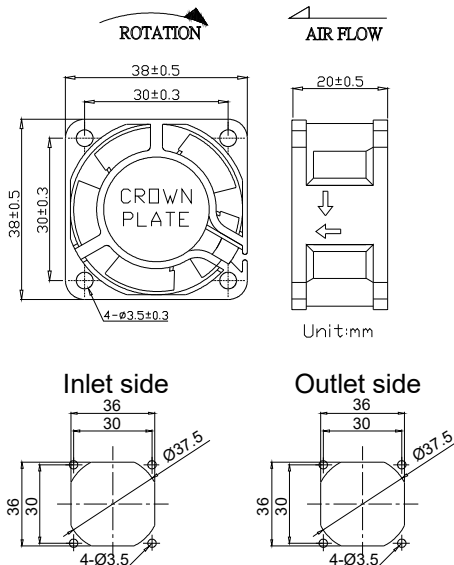

### ● Characteristic Curves

