

38

AGB series

38X38X28mm



General Specification

- Motor / DC single phase brushless motor
- Material / Frame : PBT (94V-0) ; Impeller : PBT(94V-0)
- Operation temp. / Two ball bearing : -10°C~70°C
FMB,sleeve Bearing : -10°C~50°C
- Storage temp. / -40°C~80°C
- Non-condensing environment
- Weight / 40g

Specification *Bearing system B:two ball bearing F:fluid bearing S:sleeve bearing

Model	*Bearing System	Rated Voltage	Operating Voltage	Rated Current	Rated Speed	Maximum Air Flow	Maximum Static Pressure	Sound Level	P-Q Curve		
P/N	B / S / F	V	V	A	RPM	m ³ /min	CFM	Pa	In-H ₂ O	dBA	No.
AGB03828_12L	B	12	7.0~13.2	0.11	8000	0.26	9.44	97.1	0.39	38	①
AGB03828_12M	B	12	7.0~13.2	0.15	10000	0.35	12.46	156.9	0.63	44	②
AGB03828_12H	B	12	7.0~13.2	0.29	13000	0.46	16.3	254.0	1.02	51	③
AGB03828_12U	B	12	7.0~13.2	0.48	15000	0.54	19.16	341.1	1.37	55	④
AGB03828_12V	B	12	7.0~13.2	0.85	17000	0.59	20.8	415.8	1.67	59	⑤

Drawing & panel out-cuts

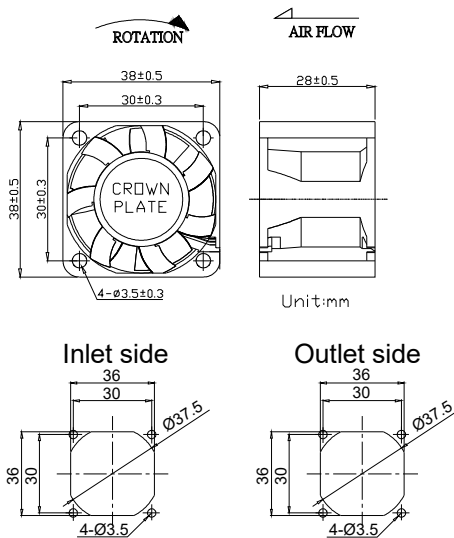

Characteristic Curves

