

40

AGK series

40X40X28mm

● General Specification

- Motor / DC single phase brushless motor
- Material / Frame : PBT (94V-0) ; Impeller : PBT(94V-0)
- Operation temp. / Two ball bearing : -10°C~70°C
FMB,sleeve Bearing : -10°C~50°C
- Storage temp. / -40°C~80°C
- Non-condensing environment
- Weight / 50g

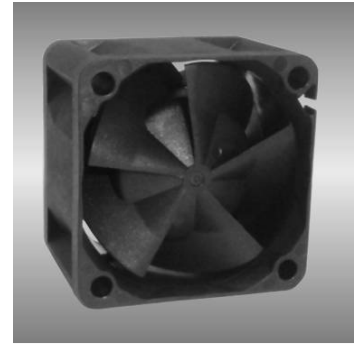

● Specification *Bearing system B:two ball bearing F:fluid bearing S:sleeve bearing

Model	*Bearing System	Rated Voltage	Operating Voltage	Rated Current	Rated Speed	Maximum Air Flow	Maximum Static Pressure	Sound Level	P-Q Curve		
P/N	B / S / F	V	V	A	RPM	m ³ /min	CFM	Pa	In-H ₂ O	dBA	No.
AGK04028B12U	B	12	7.0~13.2	0.75	21000	0.67	23.52	313.7	1.26	60	①
AGK04028B12V	B	12	7.0~13.2	0.90	23000	0.73	25.76	376.0	1.51	62	②
AGK04028B12W	B	12	7.0~13.2	1.00	25000	0.84	28.00	445.7	1.79	65	③

● Drawing & panel out-cuts

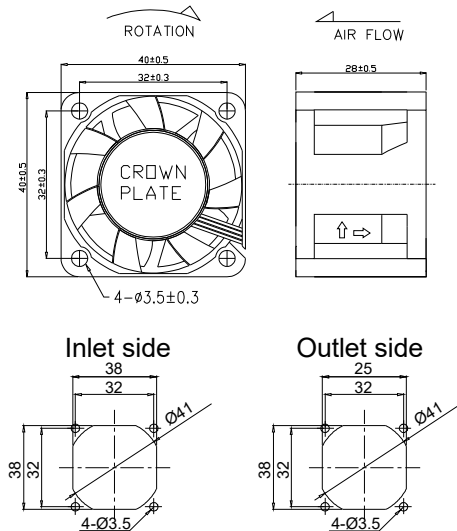

● Characteristic Curves

