

60

AGB series

60X60X38mm

●General Specification

- Motor / DC single phase brushless motor
- Material / Frame : PBT (94V-0) ; Impeller : PBT(94V-0)
- Operation temp. / Two ball bearing : -10°C~70°C
FMB,sleeve Bearing : -10°C~50°C
- Storage temp. / -40°C~80°C
- Non-condensing environment
- Weight / 145g



●Specification *Bearing system B:two ball bearing F:fluid bearing S:sleeve bearing

Model	*Bearing System	Rated Voltage	Operating Voltage	Rated Current	Rated Speed	Maximum Air Flow	Maximum Static Pressure	Sound Level	P-Q Curve		
P/N	B / S / F	V	V	A	RPM	m³/min	CFM	Pa	In-H ₂ O	dB(A)	No.
AGB06038B12I	B	12	7.0~13.2	0.52	8000	1.22	43.1	224.5	0.90	51	①
AGB06038B12J	B	12	7.0~13.2	0.68	9000	1.44	50.8	295.1	1.19	54	②
AGB06038B12L	B	12	7.0~13.2	1.00	10000	1.56	55.2	351.0	1.41	57	③
AGB06038B12M	B	12	7.0~13.2	1.38	12000	1.91	67.3	515.6	2.07	62	④
AGB06038B24L	B	24	14.0~26.4	0.22	8000	1.22	43.1	224.5	0.90	51	①
AGB06038B24M	B	24	14.0~26.4	0.40	9000	1.44	50.8	295.1	1.19	54	②
AGB06038B24H	B	24	14.0~26.4	0.53	10000	1.56	55.2	351.0	1.41	57	③
AGB06038B24U	B	24	14.0~26.4	0.75	12000	1.91	67.3	515.6	2.07	62	④

● Drawing & panel out-cuts

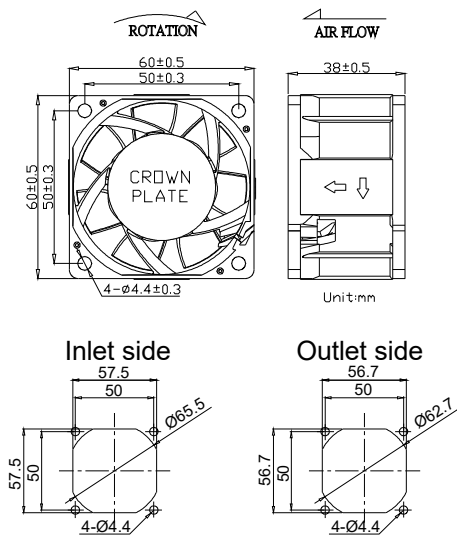

● Characteristic Curves

