

# 70

## AGE series

### 70X70X15mm

#### ●General Specification

- Motor / DC single phase brushless motor
- Material / Frame : PBT (94V-0) ; Impeller : PBT(94V-0)
- Operation temp. / Two ball bearing : -10°C~70°C  
FMB,sleeve Bearing : -10°C~50°C
- Storage temp. / -40°C~80°C
- Non-condensing environment
- Weight / 50g



#### ●Specification \*Bearing system B:two ball bearing F:fluid bearing S:sleeve bearing

Model	*Bearing System	Rated Voltage	Operating Voltage	Rated Current	Rated Speed	Maximum Air Flow	Maximum Static Pressure	Sound Level	P-Q Curve		
P/N	B / S / F	V	V	A	RPM	m³/min	CFM	Pa	In-H <sub>2</sub> O	dBA	No.
AGE07015_12J	B / S	12	7.0~13.2	0.10	2800	0.60	21.1	22.4	0.09	27	①
AGE07015_12L	B / S	12	7.0~13.2	0.12	3300	0.73	25.7	32.4	0.13	31	②
AGE07015_12M	B / S	12	7.0~13.2	0.17	3800	0.84	29.6	42.3	0.17	35	③
AGE07015_12H	B / S	12	7.0~13.2	0.25	4300	0.95	33.5	54.8	0.22	39	④
AGE07015_24M	B / S	24	14.0~26.4	0.10	3800	0.84	29.6	42.3	0.17	35	③
AGE07015_24H	B / S	24	14.0~26.4	0.12	4300	0.95	33.5	54.8	0.22	39	④

#### ● Drawing & panel out-cuts

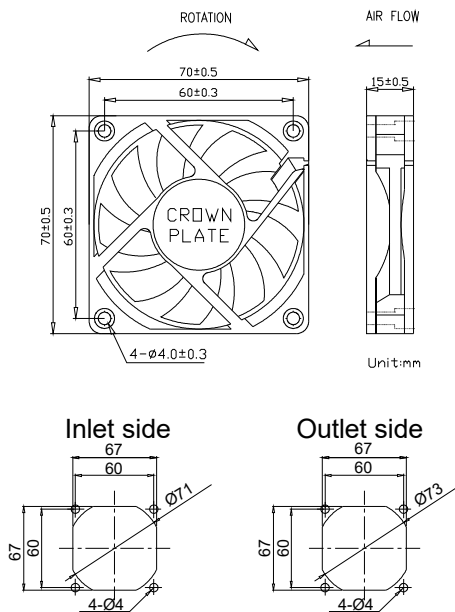

#### ● Characteristic Curves

