

70

AGE series

70X70X25mm

● General Specification

- Motor / DC single phase brushless motor
- Material / Frame : PBT (94V-0) ; Impeller : PBT(94V-0)
- Operation temp. / Two ball bearing : -10°C~70°C
FMB,sleeve Bearing : -10°C~50°C
- Storage temp. / -40°C~80°C
- Non-condensing environment
- Weight / 74g



● Specification *Bearing system B:two ball bearing F:fluid bearing S:sleeve bearing

Model	*Bearing System	Rated Voltage	Operating Voltage	Rated Current	Rated Speed	Maximum Air Flow	Maximum Static Pressure	Sound Level	P-Q Curve		
P/N	B / S / F	V	V	A	RPM	m³/min	CFM	Pa	In-H ₂ O	dBA	No.
AGE07025_12L	B / S	12	7.0~13.2	0.07	3000	0.85	30.0	37.4	0.15	27	①
AGE07025_12M	B / S	12	7.0~13.2	0.09	3600	1.02	35.6	54.8	0.22	32	②
AGE07025_12H	B / S	12	7.0~13.2	0.13	4000	1.13	39.9	67.2	0.27	37	③
AGE07025_12U	B	12	7.0~13.2	0.16	5500	1.55	54.8	124.5	0.50	45	④
AGE07025_24L	B / S	24	14.0~26.4	0.05	3000	0.85	30.0	37.4	0.15	27	①
AGE07025_24M	B / S	24	14.0~26.4	0.06	3600	1.02	35.6	54.8	0.22	32	②
AGE07025_24H	B / S	24	14.0~26.4	0.08	4000	1.13	39.9	67.2	0.27	37	③
AGE07025_24U	B	24	14.0~26.4	0.35	5500	1.55	54.8	124.5	0.50	45	④
AGE07025_48L	B / S	48	28.0~56.0	0.04	3000	0.85	30.0	37.4	0.15	27	①
AGE07025_48M	B / S	48	28.0~56.0	0.05	3600	1.02	35.6	54.8	0.22	32	②
AGE07025_48H	B / S	48	28.0~56.0	0.07	4000	1.13	39.9	67.2	0.27	37	③

● Drawing & panel out-cuts

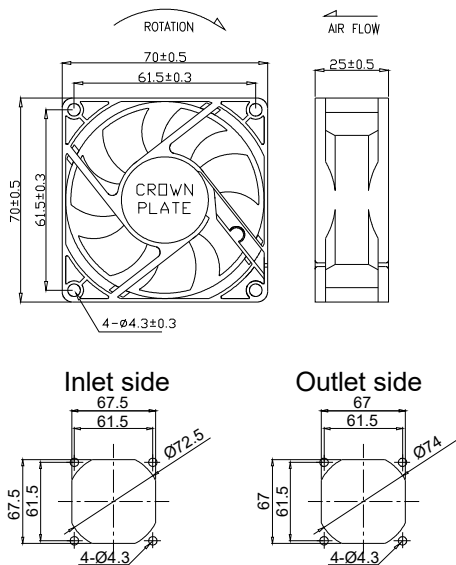

● Characteristic Curves

