

80

AGE series

80X80X20mm

●General Specification

- Motor / DC single phase brushless motor
- Material / Frame : PBT (94V-0) ; Impeller : PBT(94V-0)
- Operation temp. / Two ball bearing : -10°C~70°C
FMB,sleeve Bearing : -10°C~50°C
- Storage temp. / -40°C~80°C
- Non-condensing environment
- Weight / 76g



●Specification *Bearing system B:two ball bearing F:fluid bearing S:sleeve bearing

Model	*Bearing System	Rated Voltage	Operating Voltage	Rated Current	Rated Speed	Maximum Air Flow	Maximum Static Pressure	Sound Level	P-Q Curve		
P/N	B / S / F	V	V	A	RPM	m³/min	CFM	Pa	In-H ₂ O	dB(A)	No.
AGE08020_12J	B / S	12	7.0~13.2	0.13	2400	0.78	27.4	22.4	0.09	25	①
AGE08020_12L	B / S	12	7.0~13.2	0.16	2700	0.88	31.2	27.4	0.11	29	②
AGE08020_12M	B / S	12	7.0~13.2	0.18	3100	1.04	36.9	37.4	0.15	34	③
AGE08020_12H	B / S	12	7.0~13.2	0.24	3400	1.15	40.5	44.8	0.18	36	④
AGE08020_12U	B / S	12	7.0~13.2	0.30	4300	1.45	51.2	69.7	0.28	43	⑤
AGE08020_24J	B / S	24	14.0~26.4	0.07	2400	0.78	27.4	22.4	0.09	25	①
AGE08020_24M	B / S	24	14.0~26.4	0.12	3100	1.04	36.9	37.4	0.15	34	③
AGE08020_24U	B / S	24	14.0~26.4	0.20	4300	1.45	51.2	69.7	0.28	43	⑤

● Drawing & panel out-cuts

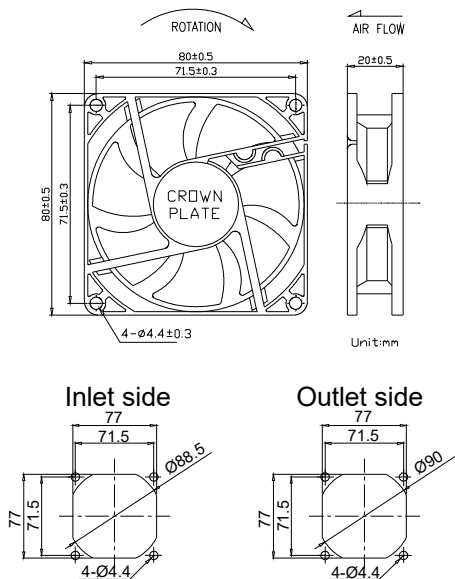

● Characteristic Curves

