

80

AGE series

80X80X15mm

●General Specification

- Motor / DC single phase brushless motor
- Material / Frame : PBT (94V-0) ; Impeller : PBT(94V-0)
- Operation temp. / Two ball bearing : -10°C~70°C
FMB,sleeve Bearing : -10°C~50°C
- Storage temp. / -40°C~80°C
- Non-condensing environment
- Weight / 54g



●Specification *Bearing system B:two ball bearing F:fluid bearing S:sleeve bearing

Model	*Bearing System	Rated Voltage	Operating Voltage	Rated Current	Rated Speed	Maximum Air Flow	Maximum Static Pressure	Sound Level	P-Q Curve		
P/N	B / F / S	V	V	A	RPM	m ³ /min	CFM	Pa	In-H ₂ O	dB(A)	No.
AGE08015_12J	B / F / S	12	7.0~13.2	0.06	2400	0.62	22.0	13.2	0.05	25	①
AGE08015_12L	B / F / S	12	7.0~13.2	0.10	2700	0.78	27.5	21.9	0.09	30	②
AGE08015_12M	B / F / S	12	7.0~13.2	0.12	3100	0.89	31.5	25.6	0.10	32	③
AGE08015_12H	B / F / S	12	7.0~13.2	0.16	3600	1.07	37.6	37.1	0.15	36	④
AGE08015_12U	B / F / S	12	7.0~13.2	0.30	4500	1.28	45.2	51.2	0.21	43	⑤
AGE08015_24J	B / F / S	24	14.0~26.4	0.04	2400	0.62	22.0	13.2	0.05	25	①
AGE08015_24L	B / F / S	24	14.0~26.4	0.06	2700	0.78	27.5	21.9	0.09	30	②
AGE08015_24M	B / F / S	24	14.0~26.4	0.08	3100	0.89	31.5	25.6	0.10	32	③
AGE08015_24H	B / F / S	24	14.0~26.4	0.10	3600	1.07	37.6	37.1	0.15	36	④

● Drawing & panel out-cuts

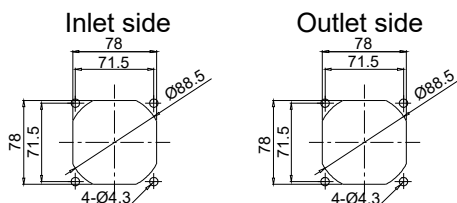
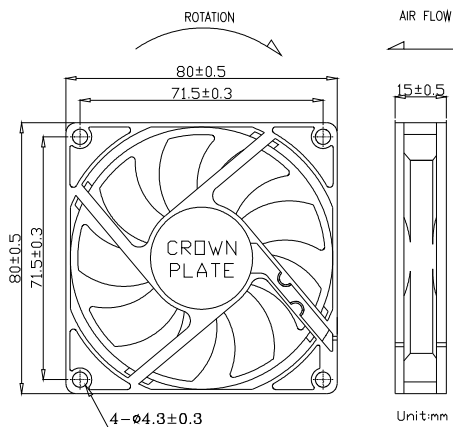

● Characteristic Curves

