

120 AGD series

120X120X25mm



● General Specification

- Motor / DC single phase brushless motor
- Material / Frame : PBT (94V-0) ; Impeller : PBT(94V-0)
- Operation temp. / Two ball bearing : -10°C~70°C
FMB,sleeve Bearing : -10°C~50°C
- Storage temp. / -40°C~80°C
- Non-condensing environment
- Weight / 155g

● Specification *Bearing system B:two ball bearing F:fluid bearing S:sleeve bearing

Model	*Bearing System	Rated Voltage	Operating Voltage	Rated Current	Rated Speed	Maximum Air Flow	Maximum Static Pressure	Sound Level	P-Q Curve		
P/N	B / S / F	V	V	A	RPM	m³/min	CFM	Pa	In-H ₂ O	dBA	No.
AGD12025_12H	B	12	7.0~13.2	0.28	2500	3.15	111.2	54.8	0.22	44	①
AGD12025_12U	B	12	7.0~13.2	0.47	3100	3.55	125.4	72.2	0.29	48	②
AGD12025_24H	B	24	14.0~26.4	0.25	2500	3.15	111.2	54.8	0.22	44	①
AGD12025_24U	B	24	14.0~26.4	0.30	3100	3.55	125.4	72.2	0.29	48	②
AGD12025_48H	B	48	28.0~56.0	0.10	2500	3.15	111.2	54.8	0.22	44	①
AGD12025_48U	B	48	28.0~56.0	0.12	3100	3.55	125.4	72.2	0.29	48	②

● Drawing & panel out-cuts

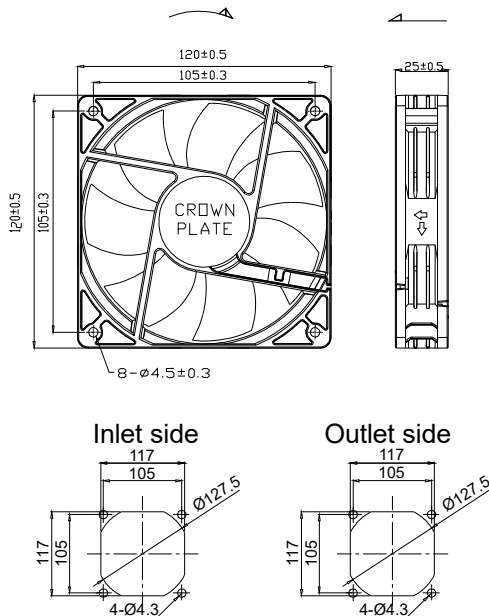

● Characteristic Curves

