

120 AGT series

120X120X25mm



● General Specification

- Motor / DC single phase brushless motor
- Material / Frame : PBT (94V-0) ; Impeller : PBT(94V-0)
- Operation temp. / Two ball bearing : -10°C~70°C
FMB,sleeve Bearing : -10°C~50°C
- Storage temp. / -40°C~80°C
- Non-condensing environment
- Weight / 230g

● Specification *Bearing system B:two ball bearing F:fluid bearing S:sleeve bearing

Model	*Bearing System	Rated Voltage	Operating Voltage	Rated Current	Rated Speed	Maximum Air Flow	Maximum Static Pressure	Sound Level	P-Q Curve		
P/N	B / S / F	V	V	A	RPM	m ³ /min	CFM	Pa	In-H ₂ O	dBA	No.
AGT12025_12J	B	12	7.0~13.2	0.15	1500	1.77	62.4	20.2	0.08	30	①
AGT12025_12L	B	12	7.0~13.2	0.25	2000	2.35	83.1	35.9	0.14	36	②
AGT12025_12M	B	12	7.0~13.2	0.40	2700	3.18	112.2	65.4	0.26	44	③
AGT12025_12H	B	12	7.0~13.2	0.65	3200	3.77	133.0	91.9	0.37	50	④
AGT12025_24J	B	24	14.0~26.4	0.10	1500	1.77	62.4	20.2	0.08	30	①
AGT12025_24L	B	24	14.0~26.4	0.15	2000	2.35	83.1	35.9	0.14	36	②
AGT12025_24M	B	24	14.0~26.4	0.20	2700	3.18	112.2	65.4	0.26	44	③
AGT12025_24H	B	24	14.0~26.4	0.35	3200	2.95	133.0	91.9	0.37	50	④

● Drawing & panel out-cuts

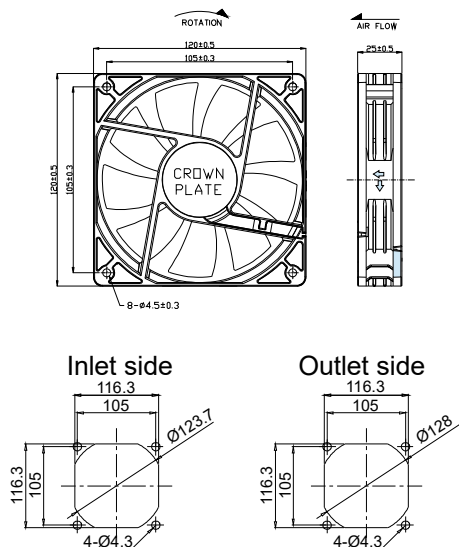

● Characteristic Curves

